

# 1. Development of an autonomous flight drone platform: Implementation of a control algorithm

## Sujet

Context: Crazyflie 2.0 is an open source project providing an environment and development tools for driving a crazyflie drone (Python and C programming).

The objective is to implement a trajectory tracking algorithm on the embedded microcontroller by modifying the current algorithm (controller and observer part).

Flight scenario tests

## Study plan

- Getting to grips with the environment (virtual machine, eclipse, python)
- Understanding the architecture and structure of existing data
- New structure / modification - development
- Tests and tests
- Real-time validation on Crazyflie 2.0 drone.

**Keywords:** Drone, embedded systems, microcontroller programming, advanced controls (Flatness based control)

## Tutors:

Pierre Riedinger, Jean Luc Metzger (Project, development method and work environment.)

Bibliographical references :

3A ISN course autonomous flight of a drone.

<https://www.bitcraze.io/development-overview/>

## 2. Data analysis ElectroRetinoGram ERG

**Tutor:** Valérie Louis Dorr

Major depressive disorder is a common mental illness with a prevalence in France of about 5%, and an estimated lifetime prevalence of 11% in men and 22% in women. This disorder, because of its health, economic and social consequences, is currently at the heart of a major public health issue. Indeed, according to the WHO, it is the leading cause of disability in terms of years of life lost in the world. One of the reasons is linked to the risk of suicide, with a depressive disorder found in nearly 80% of suicides (successful suicides) and 30 to 50% of suicide attempts. Characterized depressive disorder can occur at any age, although it occurs more frequently in young adults, especially women with a sex ratio of 2:1.

Characterized depressive disorder is defined according to the DSM V (Diagnostic and Statistical Manual of Mental Disorder V) by the persistence of mood sadness and low energy for a period of at least 15 days. The diagnosis also requires the presence during this period of at least 5 of the following symptoms: weight loss or gain, sleep disorder, psychomotor deceleration or agitation, asthenia, devaluation, concentration disorders and suicidal thoughts. However, to date, there is no examination or tool that allows the diagnosis of a characterized depressive episode to be made with certainty and to provide information on the individual prognosis of patients, even if questionnaires such as the Montgomery Asberg Depression Rating Scale (MADRS) exist to assist the clinician.

New qualitative tools could nevertheless be developed, based in particular on current studies that explore the origin of depression. There are indeed several diagnostic hypotheses, one of which relates the dysfunction of the monoaminergic system to the appearance, in certain individuals, of a characterized depressive episode. Thus, deficiencies in serotonin, noradrenaline or dopamine, hormones involved in these systems, have been measured in patients with depression. Serotonin, for example, is a neurotransmitter that, in sufficient quantity in the body, plays a positive role in regulating sleep and mood, in stress reactivity, motivation, and cognitive performance. Today, it is by addressing these deficiencies that current antidepressants contribute to clinical improvement. However, it has been shown that physiologically, light favourably impinges on the secretion of these hormones! Another hypothesis concerns disturbances in the circadian rhythm (sleep wake cycle), regulated by melatonin, which is said to have a depressant action. It is the increase in the photoperiod (the lit phase of a day-night cycle), and the decrease in melatonin, which could also explain the anti-depressive action of light.

The hypothesis underlying our research is that light therapy with a particular device concentrating light on the retina could be an effective treatment, alone or in combination with an antidepressant, to combat major depressive disorder.

We know that the retina is a good site for investigating the study of neurotransmission abnormalities in the central nervous system. The electrophysiological recording of the retina can be tested and studied using the electroretinogram (ERG).

Technically, ERG measurements are made with several types of electrodes that are placed on the surface of the eye or on the skin of patients. ERG is an objective and non-invasive measure of the electrical potential generated by the retina in response to light stimulation. This bipotential results from a change in current flowing through the retinal cells and is at the origin of the response recorded at the ERG. The signal emitted at each step determines the response of the next step (Fig. 1), in series, up to the visual areas. Depending on the nature, stimulation mode and choice of recorded signal, it is possible to collect the response of the photopic or scotopic system as well as that of the level preferentially activated.

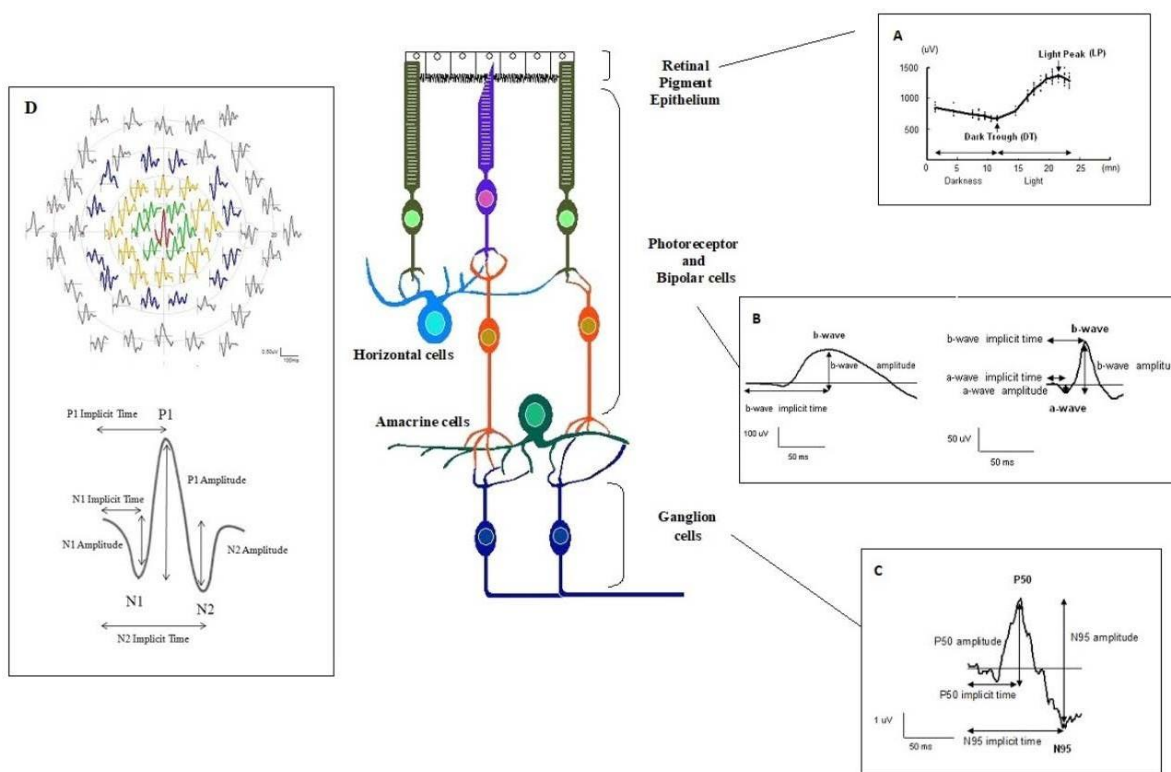

Figure 1: ERG responses by different retinal cells.

## Objectives of the project

We therefore wish to evaluate, at several phases of treatment and during post-remission follow-up, three populations with 25 participants each:

- a healthy population;
- a population with a diagnosis of depressive episode characterized by usual management and placebo light therapy;
- a population with a depressive diagnosis characterized by treatment by usual management and light therapy with special device.

To do this, an ERG will be performed in each patient on the first day D0 of the study, at 4 weeks, 8 weeks and 12 weeks. We will study possible retinal functional abnormalities and their evolution in each patient population.

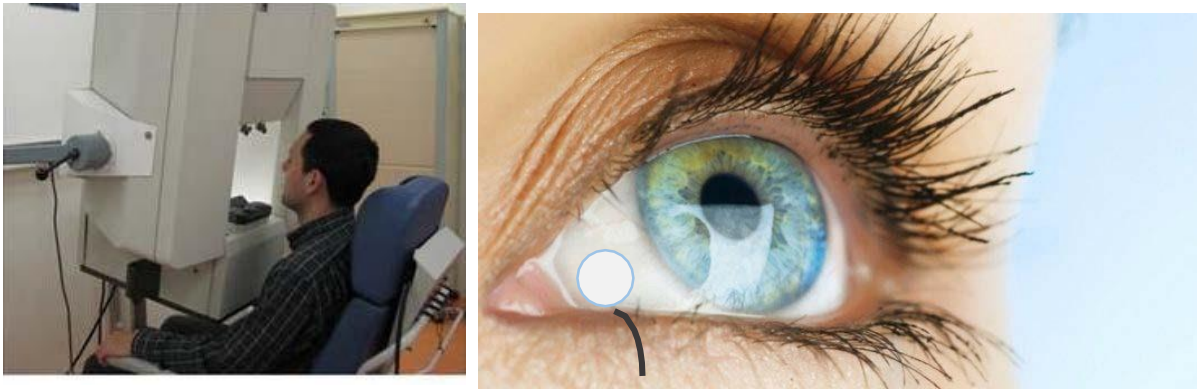

Figure 2: Stimulation and ERG electrodes

### Methodology

The ERG data will be collected at a psychiatric hospital. Our objective is to develop statistical tools for data analysis to better represent these ERG data and to classify these patients according to their characteristics. The processing consists of 4 steps:

- Creation of the data database to be continued
- Data pre-processing: linear, non-linear filtering denoising  $\mathcal{J}$  does
- Extraction of characteristics: maximum-minimum amplitudes, latency
- Applying a supervised classification algorithm
- Development of a Human Machine Interface ( to be continued in collaboration with psychiatrists)
- Statistical analysis: accuracy, sensitivity, reliability, robustesse  $\mathcal{J}$  to be done Available

Development software: Matlab, pre-processing algorithm, primary human-machine interface, database

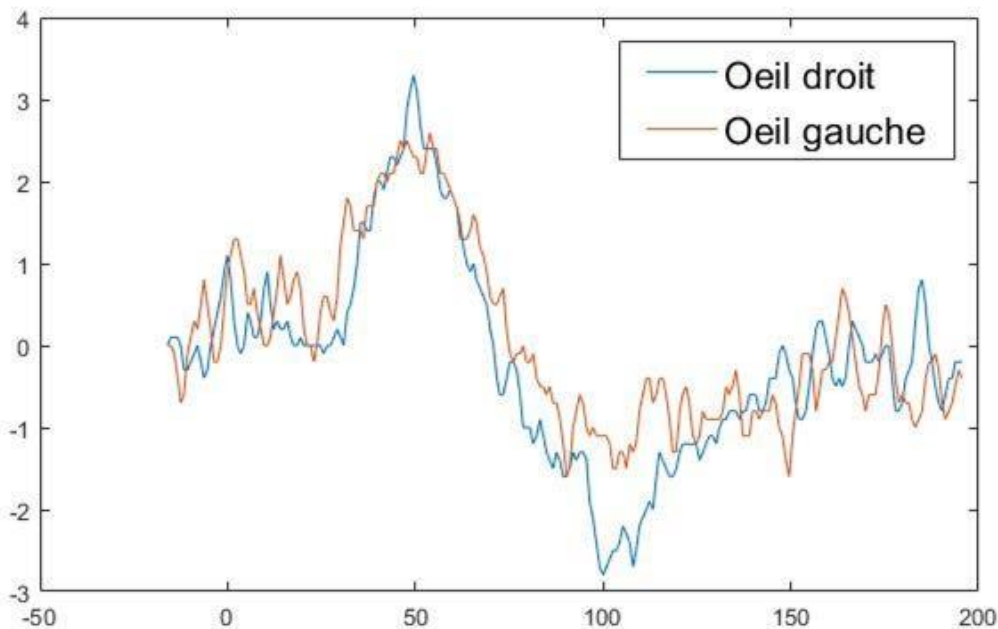

Figure 3: Potentials evoked in the retina

### 3. Modeling a time series

#### Project description

A time series is a series of numerical values representing the evolution of a specific quantity over time. Such sequences of values can be expressed mathematically in order to analyze their behavior, generally to understand their past evolution and often to predict their future behavior.

The autoregressive model is one of the most widely used techniques for time series analysis. Its principle is to predict a future sample from some previous samples. This prediction then allows the detection of a behavioral anomaly.

The objective of this project is to model a Mackey-Glass time series that provides a model of the evolution of blood cell production. It is defined by the following differential equation

$$\frac{dx(t)}{dt} = 0.1x(t) - \frac{0.2(t-\tau)}{1+x(t-\tau)^{10}}$$

For  $\tau$  values greater than 16.8, this time series has a strange attractor and the trajectories show a highly chaotic non-linear behavior. For  $\tau = 30$ , the time series is designated as MG30

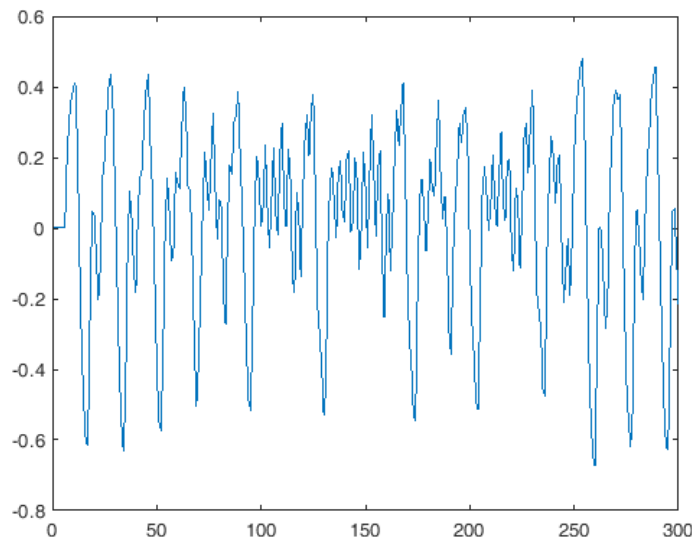

#### Study plan

Bibliographical study on the autoregressive model, the architecture to be chosen and the choice of the method for estimating the parameters of this model for the learning phase and the test to verify the performance of the proposed model

**Keywords :** Modeling, autoregressive model, Mackey-Glass

**tutor:** Maya Kallas

#### Bibliographical references

H. Madsen. *Time Series Analysis*. Texts in Statistical Science. Chapman & Hall/CRC, 2008

M.J. Collie, D.L. Dowe and L.J. Fitzgibbon. *Stock Market simulation and inference technique*, in 5<sup>th</sup> International Conference on Hybrid Intelligent Systems, 2005

J. Benesty, J. Chen and Y. Huang. *Linear Prediction*, in Springer Handbook of Speech Processing, 2008

## **4. Machine learning approaches (ML) to detect attacks on a micro-grid**

### **Topic**

Micro-grids are essential components in the deployment and integration of smart-grid systems. A micro-grid essentially relies on a centralized control model to regulate voltage stability. Recently, several studies have proposed distributed and hierarchical control models.

The security and analysis of attacks on these electrical networks involving physical models of the electrical network, control models and computer algorithms is an important task for their protection and the identification of their weaknesses. In this context, we have identified in recent work[1] a stealth attack that alters the instructions of distributed control in a micro-grid. We also implemented an experimental platform[2] to validate this attack. The platform is based on Raspberry Pi and Arduino modules coupled with electrical generators to emulate the behavior of a micro-grid.

**In this project we wish to extend this simplified experimental platform with a micro-grid to detect this attack and differentiate it from failures by using Machine Learning algorithms.**

### **Study design**

This project includes the following phases: (i) study the attack proposed in[1] and propose failure and failure models to be implemented on the experimental platform; (ii) implement detection approaches; (iii) analyze and validate detection approaches.

### **Keywords :**

Microgrid, security, attack, distributed control, machine learning

### **Tutor:**

Abdelkader Lahmadi

### **Bibliographical references**

[1] Mingxiao MA, Abdelkader Lahmadi. On the Impact of Synchronization Attacks on Distributed and Cooperative Control in Microgrid Systems. IEEE SmartGridComm 2018.

[2] Mingxiao Ma, Abdelkader Lahmadi, Isabelle Chrisment, Demonstration of Synchronization Attacks on Distributed and Cooperative Control in Microgrids, IEEE IM 2019.

## 5. Diagnostic modeling based on Luenberger observers

### Introduction

Scientific and technological progress has made a significant contribution to the development of competitive industrial systems. These systems are becoming more and more complex and their behaviour becomes difficult to assess when they are subject to disruptions.

These disruptions can lead the system into a state of failure, which can have a considerable impact on socio-economic issues related to human and equipment safety, the environment and productivity (examples: explosion in an oil/nuclear site, accidents in a transport system, etc.).

Therefore, the assessment of operational safety and its factors is crucial to controlling the risks induced by system failures.

The operational safety is therefore called into question in the event of defects in the system (or its components).



To make the system more reliable, functions and structures (hardware and/or functional) are implemented to tolerate a defect and minimize its effect on the system. For example, functions such as diagnostics to detect and locate possible malfunctions, or reconfiguration to adapt control laws or the system's hardware architecture to hazards (Fig. 1).

This type of fault-tolerant structure is found in safety-critical systems such as transport systems (Fig. 2).

The example in (Fig. 2) shows the importance of several things: redundant architectures (hardware redundancy on sensors, actuators, etc.), fault detection and isolation functions (diagnosis) and reconfiguration of the control.

The example in (Fig. 2) shows the importance of several things: redundant architectures (hardware redundancy on sensors, actuators, etc.), fault detection and isolation functions (diagnosis) and reconfiguration of the control.

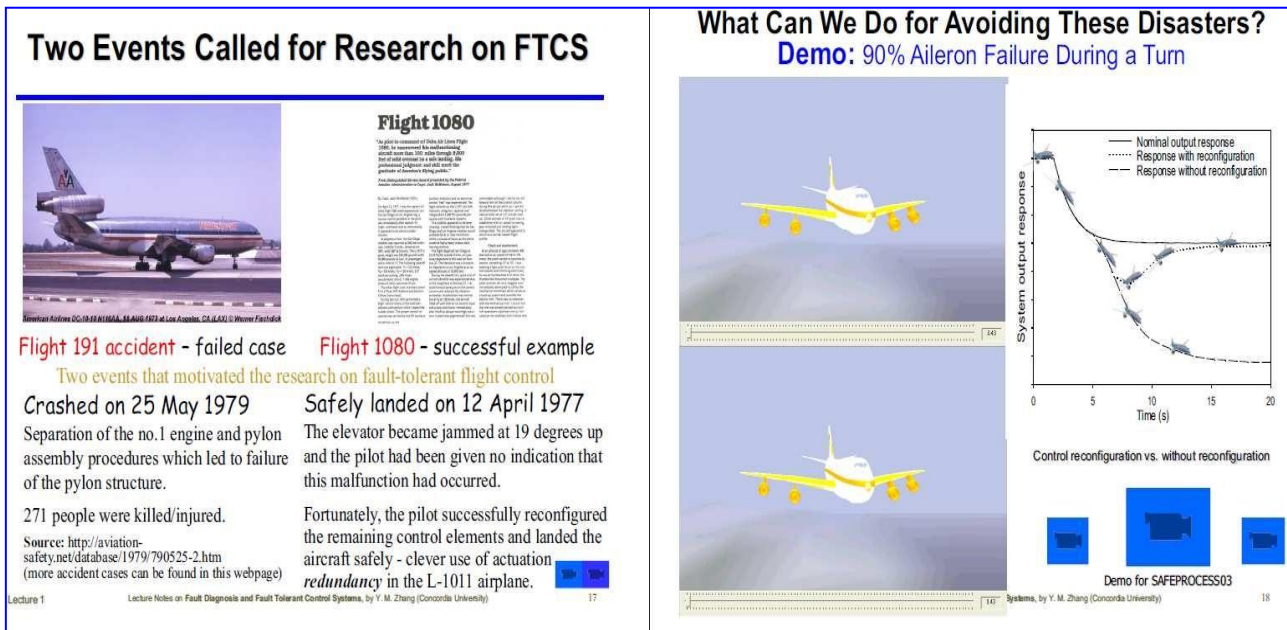

Figure 2. Example demonstrating the value of fault tolerance functions (Redundancy-Diagnosis-Reconfiguration).

### Project description

- \* It is now clear that the diagnostic function plays a key role in fault-tolerant systems since it is through it that other actions to improve system reliability/availability (e.g. maintenance and reconfiguration) can take place.
- \*
- \* The objective of this project is to study defect diagnosis by the Luenberger observer bench method. Indeed, in previous years we have seen how to use such an observer for ordering purposes. In the diagnostic module and this project, we will see how to use it for fault detection[Maquin 14][Maza 14].
- \*
- \* Two students from ENSEM started to process the modelling of an observer bank by the SANs in an IEPT[LegBouch, 2015]. What is asked for here:
- \*
- \* \* Redo a simpler SAN model of the diagnostic system than the one developed in 2015. Test it in simulation.
- \* \* Study in simulation the impact of diagnostic parameters (such as threshold, eigenvalues) on the reliability performance of the supervised system (FMDS parameters) as well as the overall system.

### Study design

- 1- Bibliographic study.
- 2- Resume the work of previous IEPTs on the synthesis of an observer bench for fault diagnosis.
- 3- Mobius study and performance evaluation.

### Keywords :

Operational safety, Diagnosis, Observer, Fault tolerance.

**Tutor : Samia MAZA**

## Bibliographical references

- ✚ [Maza, 2015] “Diagnosis modelling for dependability assessment of fault-tolerant systems based on stochastic activity networks”, *International Journal of Quality and Reliability Engineering*, Vol 31. Issue 6, pp.963-976, 2015.
- ✚ [Maquin 14] **Cours de Diagnostic**-Partie I : Les systèmes continus (année univ 2014-2015).
- ✚ [Maza, 2013] “Observer-based diagnosis modelling using Stochastic Activity Networks for the dependability assessment purpose” *2<sup>nd</sup> international conference on control and fault-tolerant systems*, Nice, Octobre 2013.
- ✚ [Maza, 2012] “Dynamic modelling and simulation of fault-tolerant systems based on stochastic activity networks” *Journal of Risk and Reliability*, 226(5), 455-463, 2012.
- ✚ [LegBouch, 2015] « Modélisation du Diagnostic à base d’observateurs de Luenberger », *projets de fin d’études ENSEM de Legay & Bouchaour*, encadrés par S.MAZA, Nancy 2015.

## 6. Development of modular and low-cost measuring instruments

### Project description

The LIEC Laboratory, an interdisciplinary laboratory of continental environments, regularly carries out field sampling of solid or liquid samples. In the case of in-situ operations requiring aqueous phase dosages, the technical tools available are often expensive and are not suitable for field use.



*Example of a syringe and burette pump in a hospital and/or laboratory environment*

The objective of this project is to study and carry out the control-command of the system actuator (stepper motor pushing the piston of the syringe). The controller card will have to perform other functions, such as communication with third-party systems. The module will be in addition to the control functions, a master interpreting or not commands for third party modules. The development will be carried out using Arduino/Uno boards.

This overall project is composed of two distinct parts: the mechanical component and the electronic/informatics component. This document presents only the electronic/informatics component. From the beginning of the project, functional specifications will be provided as well as a first version of technical specifications. These documents will serve as a basis for discussion during the first phase of exchange with LIEC teams and the drafting of consolidated technical specifications.

### Study design

- Project and demand analysis: Identification of constraints and technical solutions [ To be carried out with the Mechanical part]
- Drafting of software specifications (function, possibility of evolution), dimensioning of communication and electrical interfaces, energy balance/ projection [ To be carried out with the Mechanical part]
- Software integration, coding and testing of unit functions
- Testing and qualification of the system [ To be performed with Mechanics]

Keywords : C language, prototype, Arduino, Raspberry Pi, communication protocol (RS232/I2C/SPI), stepper motor control.  
tutors:

- Jose Paulo Pinheiro, Professor ENSG
- Vincent Dutreuil, LIEC Laboratory
- Abdelkader Lahmadi, ENSEM

### Bibliographical references

- Matheus C. Carvalho, Rachel H. Murray, Osmar:the open-source microsyringe autosampler, HardwareX, Volume 3, 2018.

## 7. Dynamic management of network quality of service by SDN

### Topic

SDN (Software-Defined Networking) is a new paradigm that is revolutionizing the world of network/Internet. It also opens up new opportunities to monitor network performance and reconfigure network equipment (e. g. switches and routers) in real time to control quality of service in terms of admission control of new flows, bandwidth allocation, routing and delays[Karakus2017].

The objective of this IEPT is to demonstrate the possibility of real-time Quality of Service (QoS) control in the context of SDN.

### Study design:

- Understand SDN and the Openflow protocol.
- Carry out a state of the art on SDN for quality of service management, i. e. ensure the collection of switch states (number of flows already allocated for example), admission control and allocation of network resources, this by limiting itself to the possibilities of the current version of the Openflow standard[Openflow].
- Prototype a controller that manages admission control and resource allocation. This controller will be based on POX (Python). As for switches that can be programmed/configured via SDN, we will use a Mininet[Mininet] network emulator.
- Supervise-Control-Reconfigure with a closed loop on the network in the sense of automatic control
- Propose an automatic controller (PD, PID,...) of QoS in or above a SDN controller (POX)

NB: This internship requires knowledge (acquired or willing to learn) in networks and Linux.

**Keywords:** QoS, SDN, Openflow, Mininet, Linux, Virtual Machine, Python, Automatic Control

**Supervision:** Ye-Qiong SONG (song@loria.fr)

### Bibliographical references :

[Karakus2017] Murat Karakus and Arjan Durrezi. 2017. Quality of Service (QoS) in Software Defined Networking (SDN). *J. Netw. Comput. Appl.* 80, C (February 2017), 200-218.

[Mininet] <http://mininet.org/walkthrough/> [Openflow]

<https://en.wikipedia.org/wiki/OpenFlow>

## 8 Simulation and experimentation of TSN networks (Time Sensitive Networks)

### Topic

Time-Sensitive Networking (TSN), is the new IEEE801.1Q standard for the implementation of real-time Ethernet networks. It is a topical subject and opens up many perspectives for all types of real-time applications (automotive, avionics, industrial control, smart grid, etc.).

The objective of this PFE is to model TSN in order to study the transfer times of critical real-time traffic (CDT: control data traffic) and flexible real-time traffic (audio/video or other). In this work, we will rely on the OMNeT++ simulation tool with the TSN models library[Falk2019]. In order to validate the model settings, we will also conduct measurements on industrial switches.

### Study design:

- state of the art on TSN performance evaluation
- study of time slot reservation algorithms in TAS (Time Aware Shaper) for critical real-time periodic traffic
- CBS (Credit-Based Shaper) study for bandwidth reservation to guarantee the worst delay of real-time flows
- introduction of the OMNeT+++ simulator with its library of TSN models[Falk2019]
- simulation of a TSN network with TAS and CBS
- performance measurement on industrial switches

**Keywords:** Real time, TSN, Simulation, Measurement, C++.

**Supervision:** Ye-Qiong SONG (song@loria.fr) and Théo Docquier (theo.docquier@loria.fr)

**Bibliographical references :** [Falk2019] Jonathan Falk, David Hellmanns, Ben Carabelli, Naresh Nayak, Frank Dürr, Stephan Kehrer, and Kurt Rothermel. NeSTiNg: Simulating IEEE time-sensitive networking (TSN) in OMNeT++. In Proceedings of the 2019 International Conference on Networked Systems (NetSys), Garching b. München, Germany, March 2019

<https://gitlab.com/ipvs/nesting>

## 9. Assessment of the reliability of multi-state systems modelled by Hasse diagram

### Topic

The objective of predictive reliability is to calculate the reliability of systems based on the knowledge of the reliability of their components. To this end, it is necessary to know how component failures and/or repairs affect the operation or malfunction of the system. These influences can be taken into account through the structure function of a system. The structure function is a function for describing the state of the system according to the states of its components and the Hasse diagram (Figure 1) is a graphical representation of this structure function.

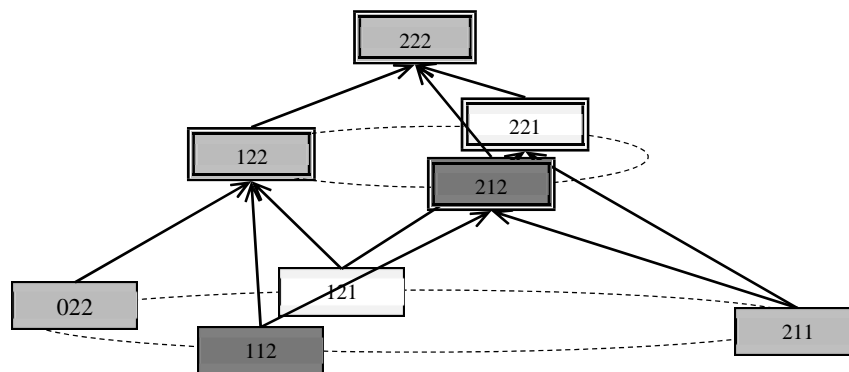

**Fig. 1.** Example of a Hasse diagram of a multi-state system.

The evaluation of the reliability of a system based on a Hasse diagram model requires first obtaining the minimum links<sup>1</sup> of a system. The theory of satisfiability (SAT), allowed us to determine the minimum links for binary systems (on/off). The structure function of a binary system is a Boolean expression that represents the state of the system as a function of the states of its components (Boolean variables). In computing, the problem of satisfiability is the decision problem that given a Boolean expression determines whether there is an assignment of variables that makes the expression true. Modulo satisfiability of theories (MTS) is the extension of satisfiability that combines logical formulas with other theories in which certain predicates or functions are expressed (e.g. integer theory, real number theory, linear structure theories such as lists, etc.)<sup>2</sup>. The structural function of a multi-state system must be able to be expressed by a logical formula combined with the theory of integers (the different states of a component can be expressed by a subset of the positive integers of which the largest integer represents the nominal state, the "0" represents the failure state and the intermediate integers represent the different degraded operating states of the component). Thus, the use of an SMT<sup>3</sup> solver will make it possible to determine the minimum links of a multi-state system from an expression describing the structure of this system.

<sup>1</sup> A link is a subset of components such that if they are all in working order while all the others are failing, the structure (system) is in working order.

<sup>2</sup> An example of a SMT formula:  $(x \in 0 \vee x \leq 4) \wedge (x = x + 1) \wedge \neg x$  or  $x$  and  $x$  are integer variables and  $x$  is a Boolean variable.

<sup>3</sup> An SMT solver is a tool (software) that determines whether an SMT formula is satisfactory against an underlying theory and provides an assignment of variables that makes the formula true. Several SMT solvers exist, for example the Z3 solver : [https://link-springer-com.bases-doc.univ-lorraine.fr/content/pdf/10.1007%2F978-3-540-78800-3\\_24.pdf](https://link-springer-com.bases-doc.univ-lorraine.fr/content/pdf/10.1007%2F978-3-540-78800-3_24.pdf) or <https://github.com/z3prover/z3>.

The minimum links will then automatically construct the system's Hasse diagram and the system reliability can then be calculated from this model.

The subject of this project concerns the study and implementation of some algorithms allowing the evaluation of the reliability of multi-state systems from a Hasse diagram model whose minimum links are determined by the use of an SMT solver. To validate this approach, the system in Figure 2 for converting DC/AC electrical power will be considered as a test case for which its minimum links and then its reliability will be determined. In this system, the "process" that performs the DC/AC conversion is a multi-state component with a nominal operating state, a failure state and degraded operating states when it does not operate at its nominal parameters. The controller and sensor have a binary behavior: on or off. Depending on the progress of the work, other systems may be studied.

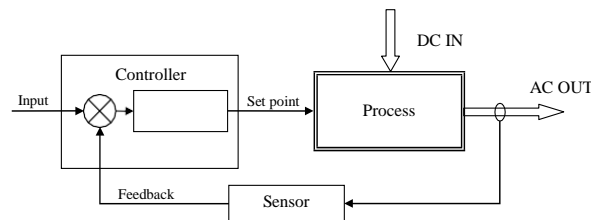

**Fig. 2.** DC/AC conversion system.

## Study design

- familiarisation with the necessary concepts: structure function, SMT, Hasse diagram
- SMT modeling of a multi-state system, its implementation and search for minimum links
- implementation of the Hasse diagram of a multi-state system and the reliability assessment algorithm
- application to some case studies to validate the work done

**Keywords:** reliability, multi-state systems, SMT (Satisfiability Modulo Theories), Hasse diagram, minimum links, reliability

**Supervision:** Nicolae Brînzei, Stephan Merz (LORIA)

## Bibliographical references

- [1] Biere, A., Heule, M., Van Maaren, H., Walsh, T., *Handbook of Satisfiability*, IOS Press, 2009.
- [2] Aubry J.F., Brînzei N., *Systems Dependability Assessment: Modeling with graphs and finite state automata*, Wiley-ISTE, (2015).
- [3] Duroeulx M., Brînzei N., Dufлот M., Merz S., "Integrating satisfiability solving in the assessment of system reliability modeled by dynamic fault trees", *29<sup>th</sup> European Safety and Reliability Conference, ESREL 2019*, Hanovre, 2019.
- [4] Aubry J.F., Brînzei N., "Weighted-graph models for reliability assessment; extension to multi-state systems", *European Safety and Reliability Conference ESREL 2016, in Risk, Reliability and Safety: Innovating Theory and Practice Safety and Reliability of Complex Engineered Systems*, CRC Press/Balkema, Taylor & Francis Group, (2017) 1451-1458

# 10. Modelling, simulation and evaluation of systems under PyCATSHOO in dynamic reliability

## Project description

*Context.* When it is necessary to assess the operational safety of complex industrial systems, it becomes necessary to take into account, from the modelling phase onwards, in addition to the dysfunctional behaviour of the system itself, also the functional behaviour of its components. While dysfunctional behaviour can generally be represented by the occurrence of discrete events (e. g. occurrence of failures, reconfigurations due to these failures to continue to ensure the mission of the system at the best possible level, etc.), functional behaviour is generally represented by the evolution of continuous physical variables describing the process implemented (e. g. temperature, pressure, liquid level in a tank, etc.). In addition, there is also the deterministic or stochastic nature of events and physical variables. All these aspects cannot be taken into account with conventional operational safety tools (failure tree, reliability diagrams, Markov chains, stochastic Petri networks, etc.). Thus, a new concept has become necessary to define all these aspects that can be involved in the evaluation of operational safety. This concept is that of dynamic reliability. In this context, we have developed at CRAN a modeling approach using Hybrid Stochastic Automata (ASH)[1, 2]. The PyCATSHOO[3] software developed by EDF allows the modelling of systems by ASH, their simulation as well as the evaluation of operating safety indicators

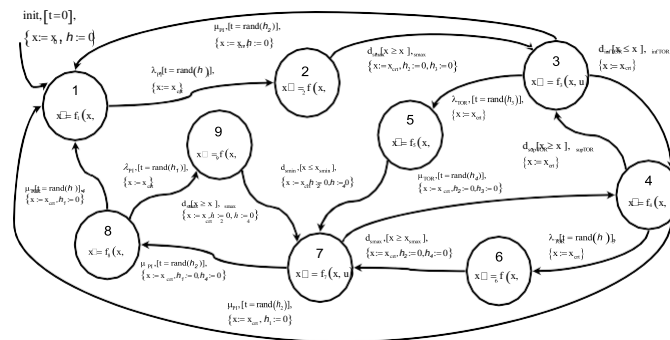
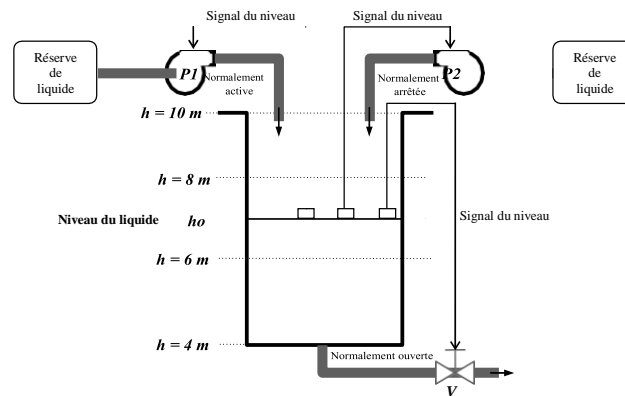

Figure 1. Example of Hybrid Stochastic PLC

In addition to the aspects presented above, some system components (e.g. human operators, control-command subsystems, etc.) must make decisions. In probability theory, stochastic decision processes have been developed to model such decisions: each time the system is observed, a decision must be made that will modify the values of the model parameters (failure rate, repair rate, etc.). This formalism has been developed and used for discrete event systems, but not in a hybrid framework.

*Proposal.* In this project, we propose to model a system using a Hybrid Stochastic Automated Systems (ASH) approach enriched with decisions. Based on the model developed under PyCATSHOO, we want to evaluate the operational safety of a system subject to decisions and study their impact. We propose to model and evaluate the operational safety of a reference test case in dynamic reliability[1, 4] (Figure 2). This is a tank in which the liquid level must be maintained between two thresholds in order to avoid the following feared events: drying out and/or

overflow. During the evolution of the system (its simulation), decisions could be taken, such as the installation of new dikes or the opening of additional breaches, etc. Then, the issue of the best decision to take will arise. Once several decisions are added to the system model under PyCATSHOO, an optimization study will be done to determine the best decision and when it should be made.



**Figure 2.** Dynamic reliability test case: a tank and its level regulation

**Keywords:** dynamic reliability, Hybrid Stochastic Automata, decision process, Monte-Carlo simulation, probabilistic evaluation

**Supervision:** Nicolae Brînzei

### Bibliographical references

- [1] Perez Castaneda G. A., Aubry J.-F., Brînzei N., “Stochastic hybrid automata model for dynamic reliability assessment”, *Proceedings of the Institution of Mechanical Engineers Part O Journal of Risk and Reliability*, 225, 1 (2011) 28-41.
- [2] Aubry J.F., Brînzei N., *Systems Dependability Assessment: Modeling with graphs and finite state automata*, Wiley-ISTE, (2015).
- [3] PyCATSHOO <http://www.pycatshoo.org/>
- [5] Aldemir T., “Computer-Assisted Markov Failure Modeling of Process Control Systems”, *IEEE Trans on Reliability*, R-36(1), (1987) 133-144.

## 11. Thermal engineering of buildings, modelling and validation

### Topic

The issue of energy management is one of the major challenges of our time and the building sector alone accounts for 40% of final energy consumption in France (source "Vision 2030-2050" by ADEME). 75% of the buildings that will be in use in 2050 are already built, so their energy renovation is one of the main areas for improvement in this sector. To this end, the Energy Performance Diagnostic, which follows the evolution of standards (RT2012...), gradually encourages owners to renovate their buildings so that their ratings (and therefore their values) do not fall.

In order to comply with these standards as effectively as possible, APHEEN1 is gradually equipping its buildings with sensors (thermal, but also weather) in order to build a reliable model of their apartments. This should make it possible to conduct energy studies with a twofold objective of energy optimization and optimization of residents' comfort. They currently have a first Modelica3 model of a common room with many sensors.

The objective of this EFP is to define and perform experiments/simulations to verify the adequacy between the model and the collected measurements (available in the form of databases). These first experiments should then make it possible to improve the existing model. Simulations can be run using MECSYCO2, a co-simulation middleware capable of linking APHEEN databases and models and running post-processing on the data obtained using the R software. The results of the PFE (models, experiments, tests, processing processes) will be packaged for reuse on APHEEN computers in subsequent studies.

### Study design

1. Getting to grips with previous work
  - a. Modelica model of the common room
  - b. Co-simulation with MECSYCO
2. Construction of experimental design (with progressive packaging)
  - a. Getting started with OpenModelica
  - b. Test construction
  - c. Analysis of data on R (reliability/verification of results)
3. Continuation of the study

### Keywords :

Building Thermal Engineering, Experimental Design, Validation

### Framing:

CHEVRIER Vincent

### Bibliographical references

Chauvière, Benoit. « Utilisation de MECSYCO et R ». Rapport de stage. Vandœuvre-lès-Nancy: ENSEM, 2019.

1 : Association Pour l'Hébergement des Étudiants et Enseignants de Nancy

2 : *Multi-agent Environment for Complex SYstem CO-simulation*, <http://mecsycoco.com/>

3 <https://www.modelica.org/>

## 12. Classification of handwritten numbers using a neural network

### Topic

The automatic recognition of handwritten numbers and letters is increasingly used for the automatic classification of letters. This classification is generally based on metadata such as the city or area where the mail is sent. In this project, we are interested in Machine Learning approaches, in particular neural networks.

The idea is to use a reference database with labelled numbers (learning set) allowing a neural network to be trained. Another database of handwritten figures will be used to test the performance of the network created. It is a question of choosing the structure of the neural network best suited to this problem.

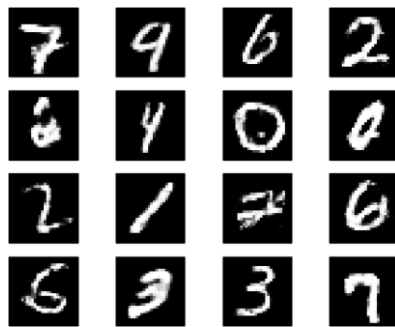

### Study design

Bibliographic study on neural networks/choice of architectures and optimization methods to better classify handwritten figures. The work will first be done under Matlab, then will be ported under Python.

**Keywords :** Pattern recognition, supervised classification, neural networks, handwritten number

**Tutors:** *Steven Le Cam, Maya Kallas*

### Bibliographical references

Michael A. Nielson, *Neural Networks and Deep Learning*, Determination press, 2015

Christopher M. Bishop, *Neural Networks for Pattern Recognition*, Oxford University press, 2005

Christopher M. Bishop, *Pattern Recognition and Machine Learning*, Springer, 2006

Andreas C. Müller and Sarah Guido, *Le Machine Learning avec Python*, O'Reilly, 2018

## 13. Learning methods for the recognition of an anomaly in a heart signal

### Project Description

The electrocardiogram (ECG) is a medical examination commonly used to assess the electrical and muscle functions of the heart. Although this is a relatively simple test to perform, the interpretation of ECG tracing requires extensive training. The electrocardiogram can measure the frequency and rhythm of the heartbeat, as well as provide indirect evidence of blood flow to the heart muscle.

The objective of this topic is to identify abnormalities in a cardiac signal using learning methods, such as probabilistic or nucleus methods, by searching for descriptors from a learning database.

A database of real ECG signals will be used, this is the database of « MIT-BIH arrhythmia database ».

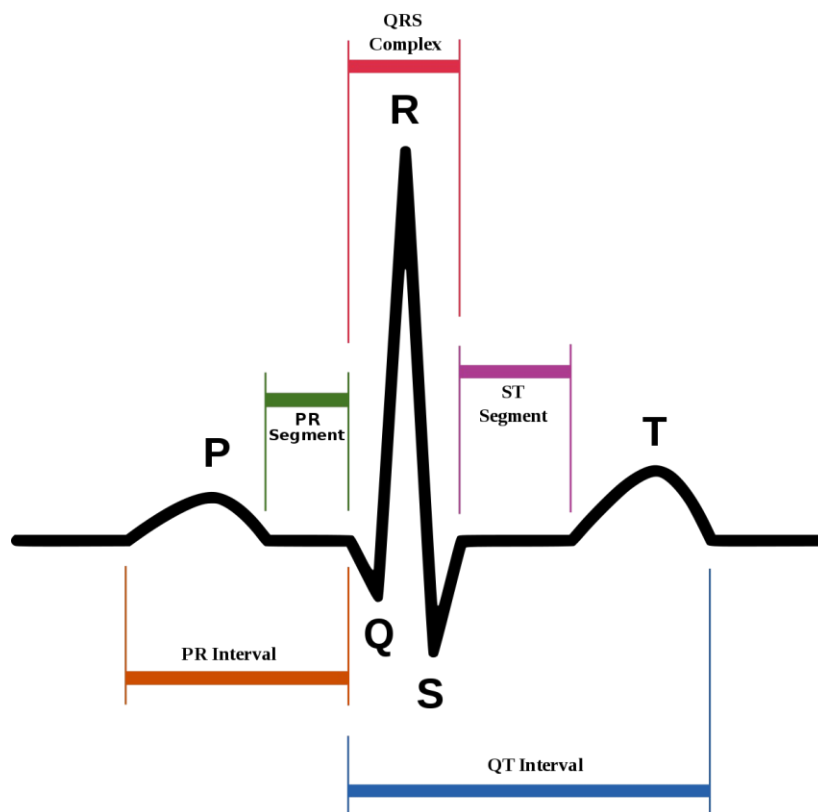

### Study design

Bibliographical study on learning methods and optimization methods to find the characteristics of a normal signal, thus facilitating the distinction of a signal with a cardiac anomaly.

**Keywords :**

Pattern recognition, feature extraction, ECG signal

**Tutors:**

*Steven Le Cam, Maya Kallas*

**Bibliographical references :**

Christopher M. Bishop, *Neural Networks for Pattern Recognition*, Oxford University press, 2005

Christopher M. Bishop, *Pattern Recognition and Machine Learning*, Springer, 2006

## **14. Automatic classification of traffic signs in a Python environment**

### **Topic**

Automatic and real-time recognition of traffic signs is a new feature of electronic equipment offered by car manufacturers. Giving vehicles the ability to integrate information into their direct environment is part of the evolution towards the advent of autonomous cars. The methods by direct comparison with a database (template matching, SIFT) have already been tested in the second year during the TWIZZY design office (ISN 2A) with some success. Nevertheless, the development of automatic learning methods should make it possible to improve classification performance.

A first step of this project is to take over the processing chain of traffic signs for the moment developed in Matlab, and develop it in Python language. The ultimate objective is to benefit from the many Machine Learning toolkits available in this language. In a second step, we will try to improve the performances obtained so far, it will be up to the student to propose a strategy based on the work of the literature, to develop it and to evaluate it.

### **Study design**

Python programming, bibliographic study, development and evaluation of a classification method

### **Keywords :**

Python, pattern recognition, automatic learning, supervised image classification

### **Tutors:**

*Maya Kallas, Steven Le Cam*

## 15. Team realization of an absolute position encoder for an Urbanloop capsule - 4 projects

### Project description

UrbanLoop is a French project, started in 2017 at ENSEM, for a dedicated and fully automated urban public transport system. This project, which is intended to be profitable and sustainable, aims to reduce traffic congestion by diverting some road traffic onto its lanes. More information on the project is available on [www.urbanloop.fr](http://www.urbanloop.fr) and is attached.

One of the major innovations to be carried out is a centimetric control of the capsules on the circuit, the need for an accurate geopositioning system must be implemented. For reasons of accuracy and safety, the GPS positioning system should not be considered. (tunnels, dependencies on other technologies)

To test this centimetric piloting, it is proposed to set up a real-time trajectory monitoring: For this purpose a roadbook is sent by wifi to the capsule from the container. This road book is a text file indicating for different moments of the journey path an exact position instruction for the capsule on the circuit. The order of magnitude of the sampling is the second. Thus a journey of a few minutes is marked by a few hundred intermediate points. A Raspberry pi on the chassis receives this text file via wifi.

To control the capsule with this setpoint, an absolute position encoder must be developed. This means that the capsule must always know its exact position on the circuit without communicating with the outside world. The precision objective is the centimeter ;

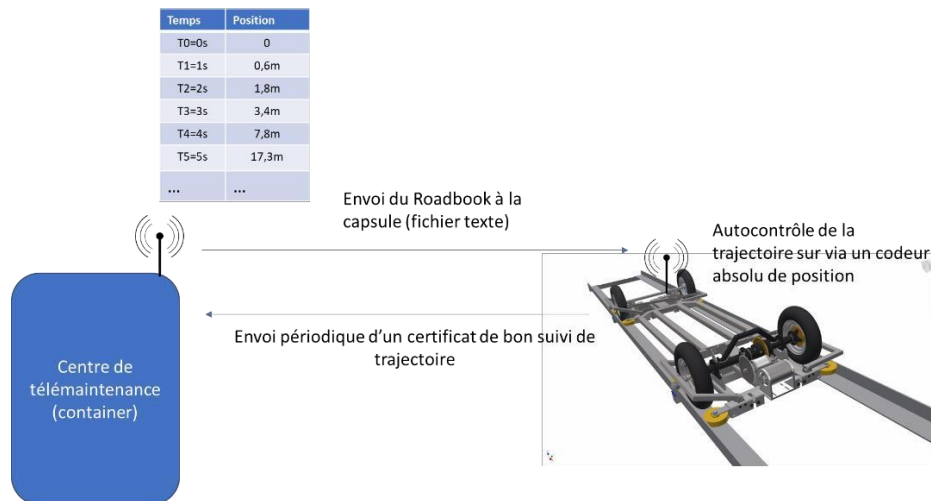

In the philosophy of Urbanloop projects, the solution chosen must be simple and already validated in the industry. Thus 3 elementary and complementary sub-modules will be associated and integrated for the absolute coding function.

- An incremental coding submodule: An incremental encoder placed on the transmission axis is used to determine the absolute position of the wheel angle. In the absence of slippage, the accuracy of the capsule positioning is equal to the perimeter of the wheel divided by the number of encoder steps. With a 1024 points per revolution encoder, the accuracy of the capsule positioning on the rail will be about 2 mm. The output signal from the encoder can be digitally derived to obtain an accurate estimate of the capsule travel speed.



*Figure 1: Example of an incremental encoder*

- A crossbar counting submodule: It is based on an inductive crossbar detection sensor: By counting only the number of wheel revolutions, with the incremental encoder, the system will gradually drift (sliding of the tires on the rail, accumulation of measurement drifts...). The absolute positioning accuracy will no longer be good. To periodically and precisely resynchronize the absolute position of the capsule on the circuit, a signal will be recovered at each traverse passage. The sleepers are about 2 metres apart and are fixed to the ground.



*Figure 2: Example of an inductive sensor*

- A barcode reader will read stickers previously affixed to the sleepers and will ensure that no sleepers have been "skipped". It is agreed that knowing the number of the traverse is exactly the same as knowing its position on the circuit. Indeed each traverse will be listed and located beforehand on the circuit and the information will be hard coded in the capsule controller (via a text file that will be loaded in the ram beforehand in the program)

### **Bibliographical references :**

Christopher Bishop, Pattern Recognition and Machine Learning, Springer, 2006 Michael Nielsen, Neural Networks and Deep Learning, Dterminationpress, 2015

John Shawe-Taylor and Nello Cristianini, *Kernel Methods for Pattern Analysis*, Cambridge university press, 2012

Sun-Yuan Kung, *Kernel Methods and Machine Learning*, Cambridge university press, 2014

The 4 proposed projects aim to control the capsule position according to the diagram below: Thanks to the combination of the information from the 3 sensors, the module reconstructs its position in real time and compares it with its theoretical position. The capsule can therefore modulate its speed to accelerate or slow down according to its timing.

3 projects are dedicated to the implementation of the 3 sensors to constitute the absolute position encoder, the last project consists of the realization of the global control system.

### **Tutor:**

*Jean-Philippe MANGEOT,*

. The 4 projects are linked but will be tested independently before being integrated

### ***Project 1: development of the absolute position module***

## **Projet 1**

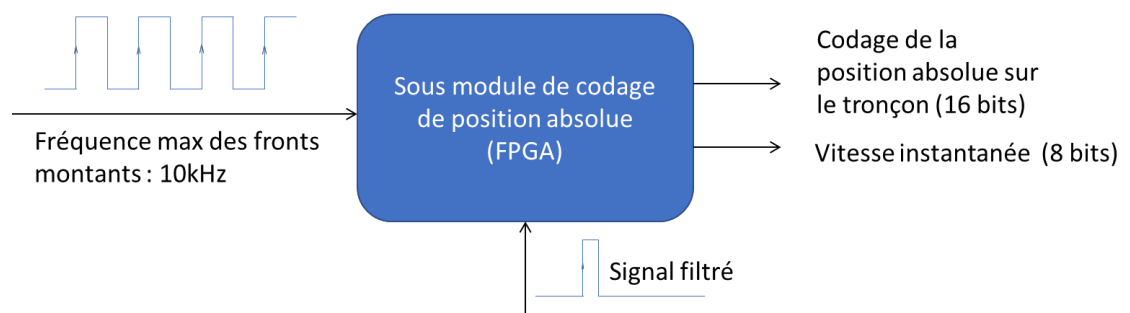

- - Writing specifications (coding rules)
- - Choosing and purchasing the incremental encoder
- - Choosing and purchasing the programmable component (FPGA)
- - Power supply and wiring of the encoder on a labdec plate
- - Program coding in VHDL
- - Laboratory tests
- - Actual tests
- - Writing of documentation

*Project 3: barcode recognition submodule*

## Projet 3

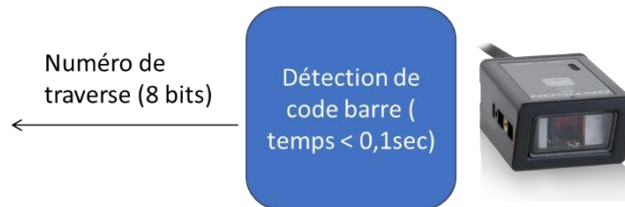

- - Writing specifications (coding rules)
- - Choice and purchase of the optical reader and identification system
- - Power supply and wiring of the encoder on a labdec plate
- - Installation and familiarization of the acquisition card (rasberry or arduino)
- - Carrying out detection measurements for each sleeper
- - Laboratory tests
- - Integration
- - Writing of documentation

*Project 2: sleeper counting submodule*

- - Writing specifications (coding rules)
- - Choice and purchase of the inductive sensor
- - Power supply and wiring of the encoder on a labdec plate
- - Installation and familiarization of the acquisition card (rasberry or arduino)
- - Carrying out detection measurements for each sleeper
- - Development of the filtarge program
- - Laboratory tests
- - Integration
- - Writing of documentation

*Project 4: Project management / integration of the solution*

Temps	Position
T0=0s	0
T1=1s	0,6m
T2=2s	1,8m
T3=3s	3,4m
T4=4s	7,8m
T5=5s	17,3m
...	...

Road book reçu par le calculateur

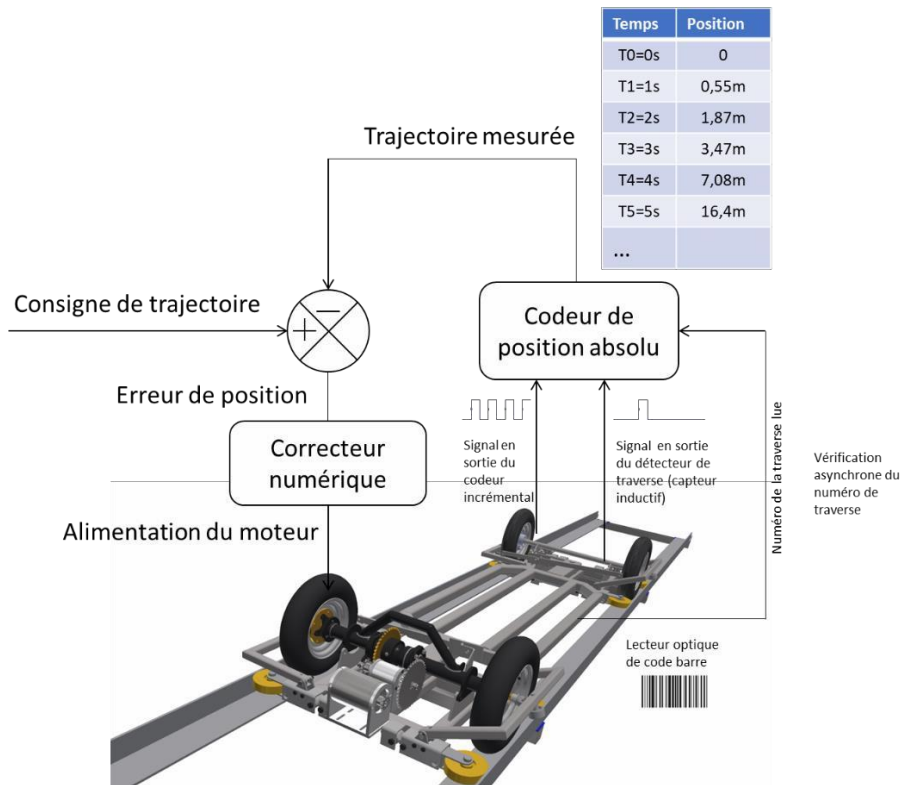

- - Writing general specifications (coding rules)
- - Review of the specifications of the other projects, writing of the test book
- - Test data management
- - Follow-up of schedules and orders
- - Design of the digital corrector program
- - Project follow-up
- - Integration and coordination of tests

## 16.Evaluation of Urbanloop's performance

Urbanloop (<http://urbanloop.univ-lorraine.fr/>) is an innovative project aimed at providing a new means of intelligent mobility to complement the current urban transport system. Its principle of individual mobility on interconnected loop circuits theoretically reduces travel time (by eliminating the waiting time for intermediate stops). But this new system is limited in terms of capacity.

The objective of this IWP is to study (probably using queue theory) the performance of an urbanloop network in terms of flow capacity, travel time as a function of flow variation in a day. This study should make it possible to understand the limits of this system and identify areas for improvement.

### Study plan:

- state of the art on the performance evaluation of an Urbanloop network
- introduction to the Urbanloop simulator (in python)[Beley2019]
- definition of an Urbanloop network to be simulated and design of a daily passenger flow model
- performance evaluation (waiting time and travel time as a function of flow density)
- suggestions for improvement (e.g., station with parallel and serial stop tracks, number of capsules per station, scheduling of the optimal movement of empty capsules, etc.)
- extension of the simulator integrating the improvement proposals

**Keywords:** Urbanloop, Simulation, Performance evaluation, Programming (Python)

**Supervision:** Ye-Qiong SONG ([song@loria.fr](mailto:song@loria.fr))

### Bibliographical references :

[Beley2019] Lucas Beley, « Bio-inspired routing for the Urbanloop project » Master's Thesis, Heriot-Watt University, 2019.

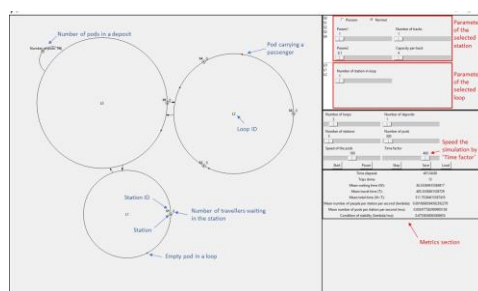

## 17.Compression algorithms under Matlab

### Project description

Compression without data loss is nowadays integrated in most compression / source encoding software (zip, pdf, jpeg,...). Several algorithms have been developed, from the first approaches (Shannon-Fano, Huffman) to the most recent solutions (LZW, arithmetic coding).

The objective of this Project is to

1) improve Huffman coding codes to obtain a complete compression/decompression tool under Matlab. This tool will have to take any file as input and save a compressed file on the disk, and vice versa. It is therefore a question of designing this tool both in terms of specifications (structure of the compressed file, header, dictionary,...) and in terms of interface.

2) implement other source coding methods, such as LZW (Lempel-Ziv-Welch), which is currently an integral part of image coding such as tiff or gif. As in the previous case, it will be necessary to define the format and create the codes and their interface.

In both cases, the codes must be accompanied by a user guide, possibly with help that can be called up from the interface.

### Keywords :

Lossless compression, Images, Interfacing, Matlab

### Supervision:

Radu Ranta

**References :** *Gonzalez and Woods*, Digital Image Processing

## **18. Interfacing electrophysiological signal analysis tools**

### **Project description**

Understanding the neural mechanisms underlying cognitive or pathological brain processes is based on the comparison of medical data of various kinds. Clinicians must map and interpret anatomical (MRI, Scanner, ...), functional (EEG, fMRI, ...) and metabolic (PET, TEMP, ...) imaging data in addition to clinical data obtained by patient examination (semiological manifestations). The reference frame, dimensions and data format are very often variable from one imaging system to another, which makes it very difficult in clinical practice to merge these images into the same anatomical space specific to the patient. A software platform addressing this issue has been developed within the team

CRAN's "Neurosciences of Systems and Cognition". ICEM (for Multimodal Brain Imaging) is designed to assist in medical diagnosis, preoperative planning and surgical decision-making.

This tool also offers the possibility of applying data processing and analysis algorithms developed by the team's researchers, in particular for data pre-processing and for the location of brain sources. These methods must be integrated into the interface over time. The purpose of this PFE is therefore to add some recent algorithms to ICEM, to optimize their user interface (multi-level menu, visualization of results), and to test these algorithms on real data sets.

In parallel, a second analysis tool called LetsWave is dedicated exclusively to the processing and analysis of electrophysiological signals, and greatly facilitates the work of neuroscience researchers in analyzing data from cognitive protocols. An additional modality has recently been collected at Nancy University Hospital, namely microrecordings that allow neural activity to be collected at the cell level. Some methods have recently been developed to process these data and rapid integration with LetsWave is needed to systematize their use.

### **Study plan**

We will focus on the entire processing chain: raw data recovery, data pre-processing, algorithm initialization and conditioning (automatic or manual), restitution and display of results in collaboration with tools already implemented in ICEM.

### **Keywords :**

Algorithm interfacing, Matlab, (S)EEG, Pre-processing, Direct and reverse problems

### **Framing:**

Radu Ranta, Steven Le Cam

### **References :**

[http://www.cran.univ-lorraine.fr/francais/plates\\_formes/22-imageriecerebralemultimodale.php](http://www.cran.univ-lorraine.fr/francais/plates_formes/22-imageriecerebralemultimodale.php)

<https://www.letswave.org/>

## 19. Python development and evaluation of a method for simulating extracellular potentials

### Project description

In order to understand the origin of brain electrophysiological activities generated by the human brain, a method to simulate the contribution of action potentials (neuron response) to extracellular potential was recently developed during Harry Tran's thesis[1]. This simulator, currently developed in Matlab, could be improved by combining it with simulation methods developed in Python, particularly within the LFPy[2] simulation environment.

A first part of the work required is to get to grips with the simulator and develop it in Python language (a few dozen lines of code). A second, more substantial part will be to improve the current simulator by coupling it with existing simulation methods mentioned above. Finally, the ability of this simulator to reproduce electrophysiological activities emitted by neurons of different morphology and nature will be evaluated.

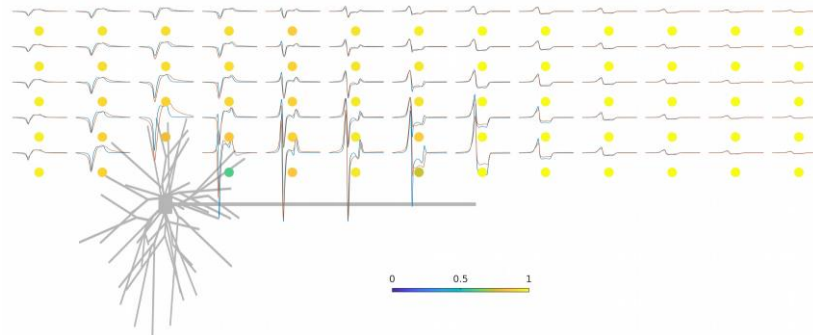

### Study plan:

simulator familiarization and development in python, integration into the LFPy simulation environment, simulator evaluation

### Keywords :

Python, computational neuroscience, simulation and analysis

### Tutors:

Radu Ranta, Steven Le Cam

**References :** Harry Tran, *Signatures extracellulaires des potentiels d'action neuronaux: modélisation et analyse*, Thèse de l'université de Lorraine, 2019.

[1] Linden *et. al.*, *LFPy: a tool for biophysical simulation of extracellular potentials generated by detailed model neurons*, Frontiers in Neuroinformatics, 2014

## 20. Model of sparse brain sources guided by an atlas

### Project description

The localization and characterization of neural electrical generators are fundamental issues for understanding healthy or pathological brain function. This localization is mainly carried out using electrophysiological recordings, a type of measurement with a very good temporal resolution. Based on a set of measurements and knowledge of a propagation model within the brain volume, it is necessary to estimate a set of sources to explain the measured data. The solution to this problem is not unique, as different source configurations can lead to the same propagation result on the sensors. Many algorithms have been developed to try to identify the desired solution from the set of eligible solutions[Baillet et al., 2001].

During this project, we are interested in studying the direct problem (or source propagation model) and its influence on the localization result. In particular, we would like to move towards parsimonious solutions where a limited number of sources make it possible to explain the measures as well as possible. In this context, the redundancy of the source dictionary must be controlled in order to optimize localization procedures (limited dictionary size) while ensuring full recovery of the volume to be explored[Tran, 2015]. Our approaches are based on clustering elements of a high-resolution dictionary using unsupervised automatic learning methods[Ranta et al., 2019]. The objective is to map these reduction methods to an atlas of the brain by associating a limited number of sources to each brain structure. The location results will be evaluated in simulation and then on actual data.

### Study plan

Bibliographical study, familiarization with methods (localization algorithm, dictionary reduction algorithm), evaluation on simulated data, analysis on real data.

### Keywords :

Matlab, (S)EEG, Direct and reverse problems, Parsimonious approaches

### Tutors:

Radu Ranta, Steven Le Cam

### References :

Baillet, S., Mosher, J. C., & Leahy, R. M. (2001). Electromagnetic brain mapping. *IEEE Signal processing magazine*, 18(6), 14-30.

Tran, H (2015), Approches parcimonieuses pour la localisation de sources cérébrales, *rapport de Master ISC, Université de Lorraine*.

Ranta, R., Le Cam, S., Bergmanis-Korats, G., Rimbart, S., & Bougrain, L. (2019). On source space resolution in EEG brain imaging for motor imagery. In *2019 9th International IEEE/EMBS Conference on Neural Engineering (NER)* (pp. 1025-1029). IEEE.